

NOTES  
 1. DRAINAGE FROM PRIVATE PROPERTY SHALL NOT BE ALLOWED TO FLOW INTO COUNTY HIGHWAY. IF NECESSARY, PERMITS WILL BE REQUIRED FOR DRAINAGE SYSTEM AT PROPOSED ROAD AND/OR DRIVEWAY INTERSECTIONS.

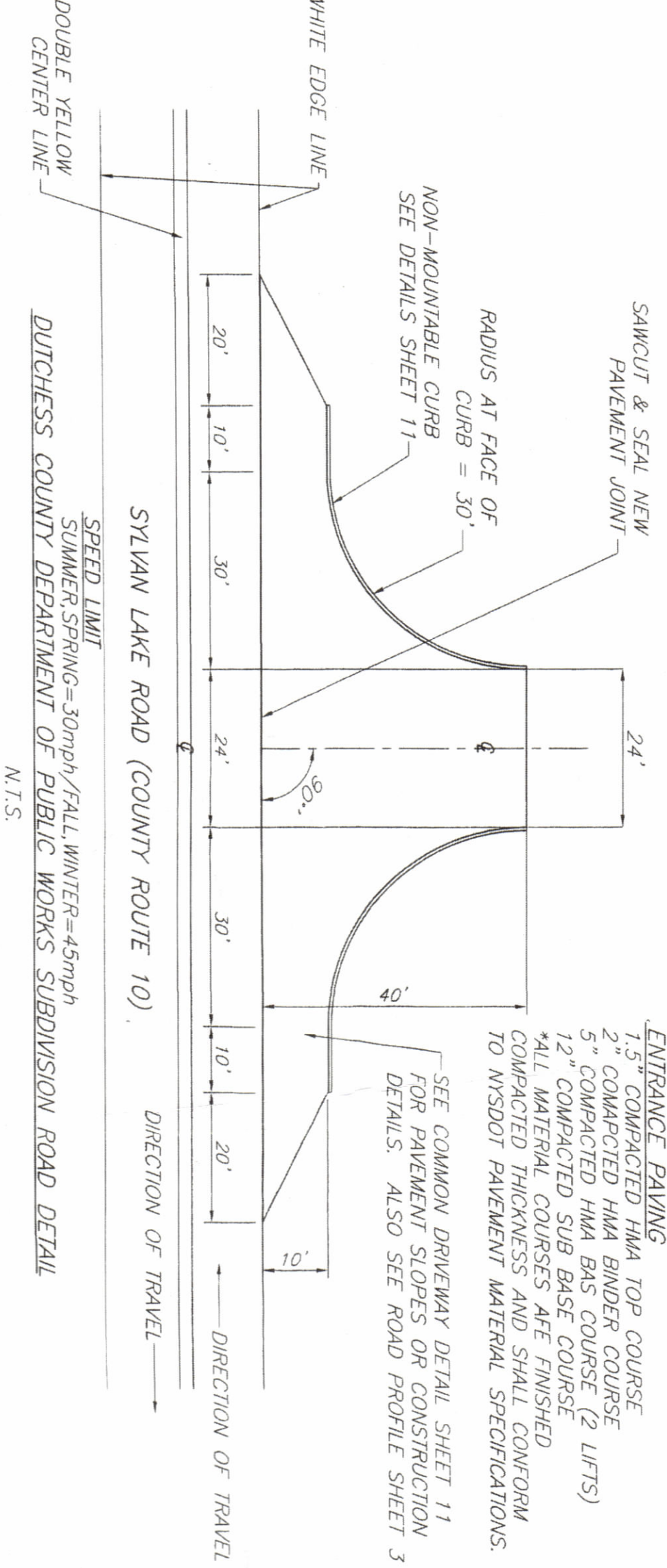

- CONDITIONS AND RESTRICTIONS
1. THIS PERMIT SHALL NOT BE ASSIGNED OR TRANSFERRED WITHOUT THE WRITTEN CONSENT OF THE COMMISSIONER OF PUBLIC WORKS.
  2. THE WORK AUTHORIZED BY THIS PERMIT SHALL BE PERFORMED UNDER THE SUPERVISION AND TO THE SATISFACTION OF THE COMMISSIONER OF PUBLIC WORKS OR HIS REPRESENTATIVE.
  3. PERMITS GRANTED BY THIS PERMIT ARE DAILY COVERED BY WORKMEN'S COMPENSATION OF PUBLIC WORKS RESERVE. THE RIGHT AT ANY TIME TO REVOKE OR ANNULL THIS PERMIT SHOULD THE SAID COMPENSATION BE FORFEITED.
  4. THE PERMITTEE AGREES TO PAY ALL NECESSARY EXPENSES INCIDENT TO SUPERVISION AND INSPECTION BY REASON OF THE GRANTING OF SUCH PERMIT AS CERTIFIED BY THE COMMISSIONER OF PUBLIC WORKS. SUCH PAYMENT TO BE MADE WITHIN TEN (10) DAYS FROM RENDERING OF THE CERTIFIED ACCOUNT.
  5. WORK UNDER THIS PERMIT TO BE COMMENCED WITHIN THIRTY (30) DAYS FROM DATE OF PERMIT AND CONTINUED IN AN EXPEDITIOUS MANNER.
  6. TRAFFIC SHALL BE MAINTAINED IN ACCORDANCE WITH THE NEW YORK STATE MANUAL OF UNIFORM TRAFFIC CONTROL DEVICES IN A SAFE MANNER DURING WORK AND EVENING HOURS UNTIL ITS FINAL COMPLETION. SUFFICIENT SIGNAGE AND LIGHTS (DEPARTMENT OF TRANSPORTATION) SHALL BE PROVIDED TO A MINIMUM.
  7. THE PERMITTEE SHALL BE FULLY RESPONSIBLE FOR MAINTAINING THE WORK SITE WITHIN THE RIGHT OF WAY INCLUDING ROAD PAVEMENT SHOULDERS, DRAINAGE STRUCTURES AND SYSTEMS IN GOOD CONDITION UNTIL AUTHORIZED PERMIT WORK HAS BEEN COMPLETED TO THE SATISFACTION OF THE DEPARTMENT. NO WORK SHALL BE DONE TO OBSTRUCT WARNING SIGNS, DRAINAGE, OR TO DIVERT WATER COURSES OR SLICES ONTO THE COUNTY ROAD RIGHT OF WAY.
  8. THE PERMITTEE, FOR HIMSELF, HIS DISTRIBUTORS, AND PERSONAL REPRESENTATIVES, COVENANTS AND AGREES TO DEFEND ANY ACTION OR JUDGMENT RECOVERED THEREIN BY OR FOR THE COUNTY OF DUTCHESS FOR NEGLIGENCE IN THE PERFORMANCE OF HIS OBLIGATIONS UNDER THIS PERMIT.
  9. THE PERMITTEE SHALL MAINTAIN ALL ITEMS CONSTRUCTED AND/OR IMPROVEMENTS AUTHORIZED BY THIS PERMIT (WITH EXCEPTION OF CHANGES OR ALTERATIONS TO THE COUNTY HIGHWAY FACILITY) WHILE THE PERMIT IS IN EFFECT.

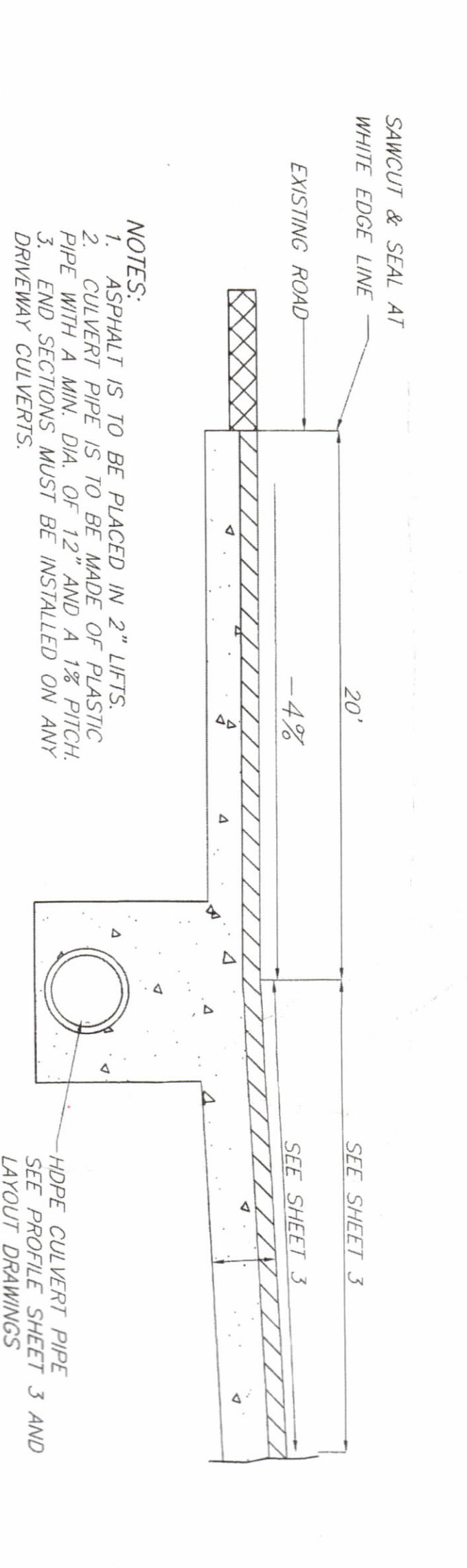

ROAD SECTION WITH GRADE DETAIL  
 N.T.S.

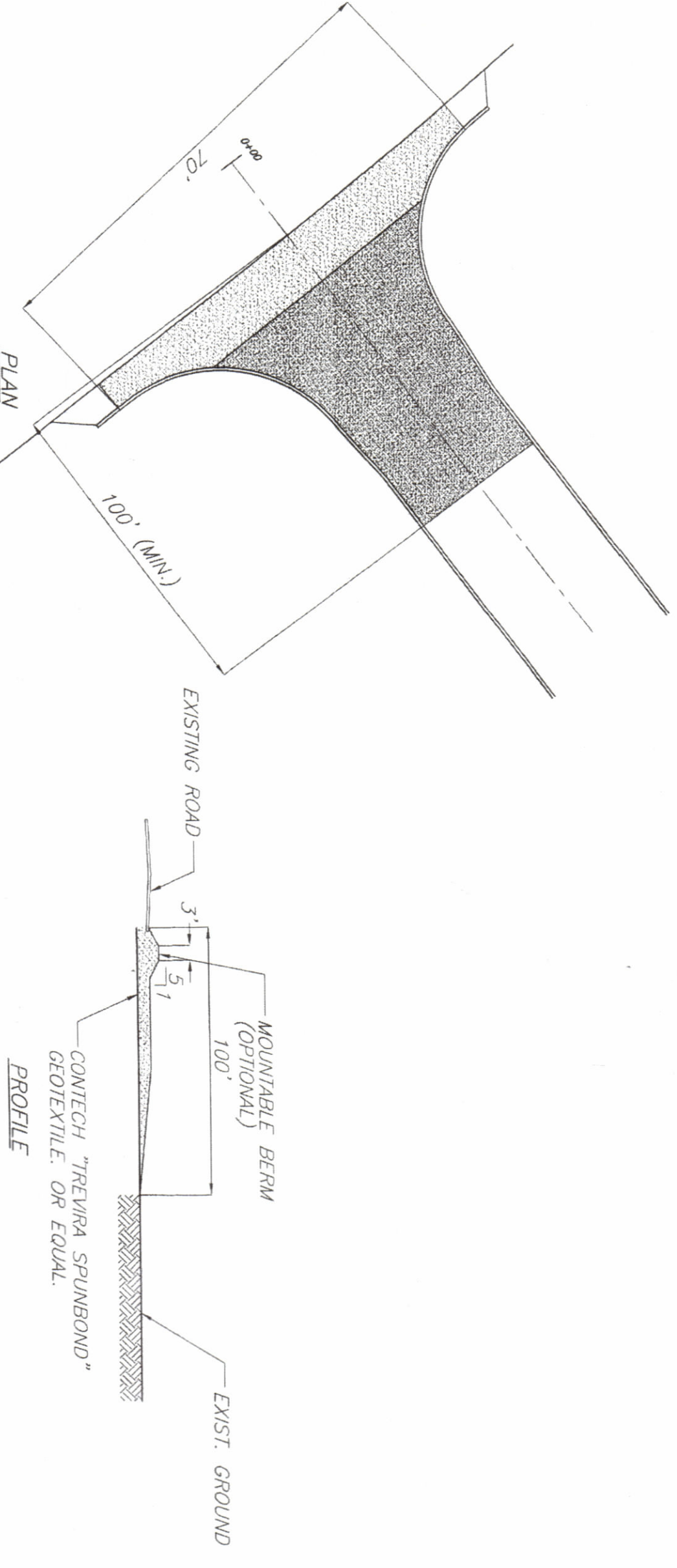

- NOTES:  
 1. STONE SIZE SHALL BE 2\"/>

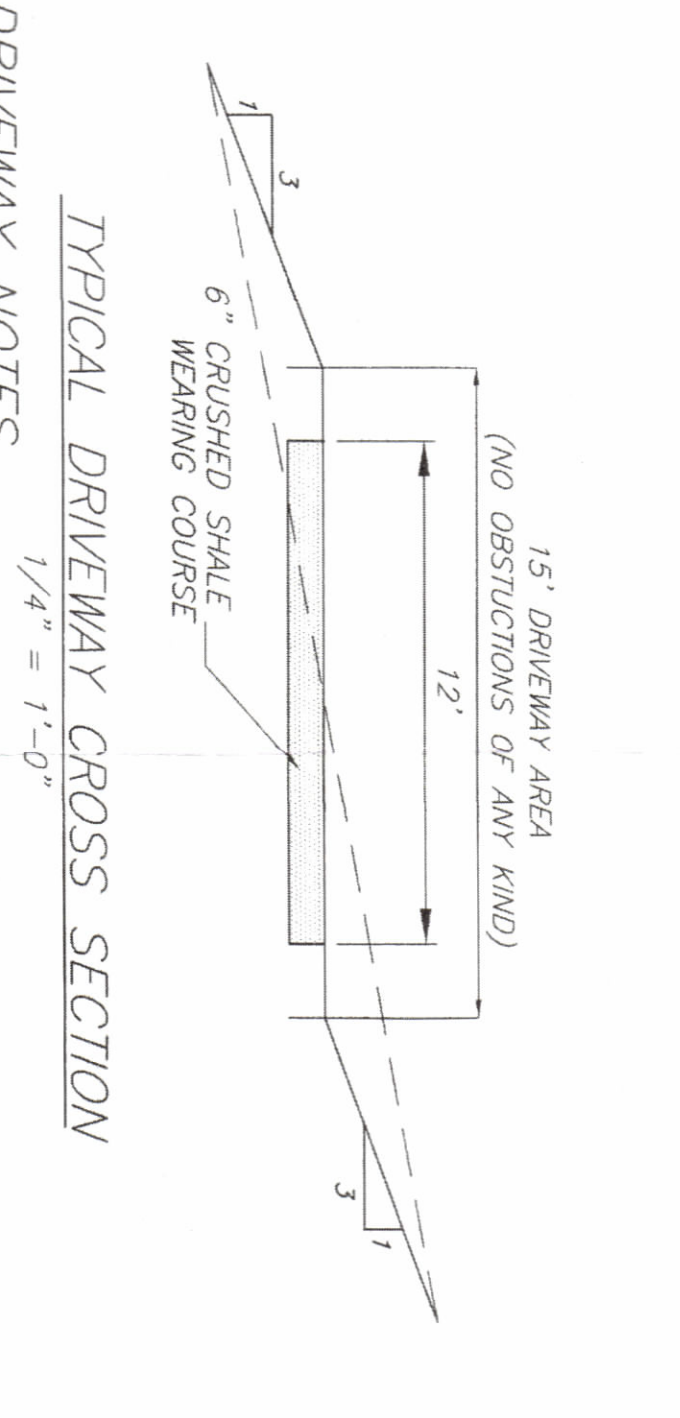

TYPICAL DRIVEWAY CROSS SECTION  
 1/4" = 1'-0"

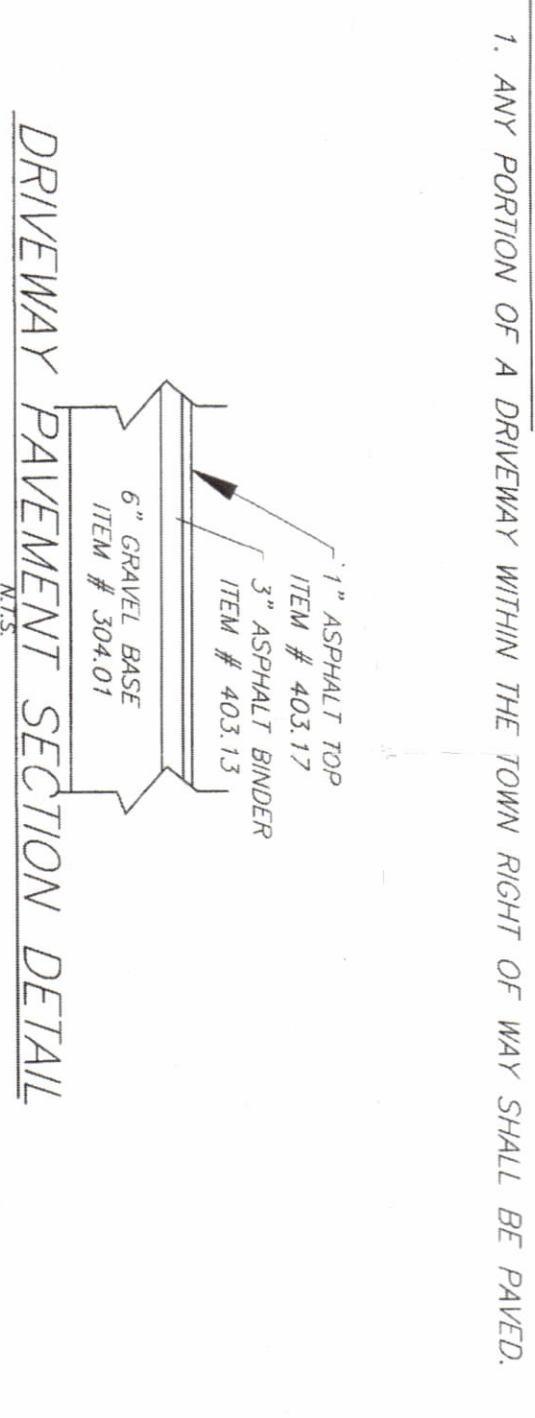

TYPICAL DRIVEWAY ENTRANCE  
 N.T.S.

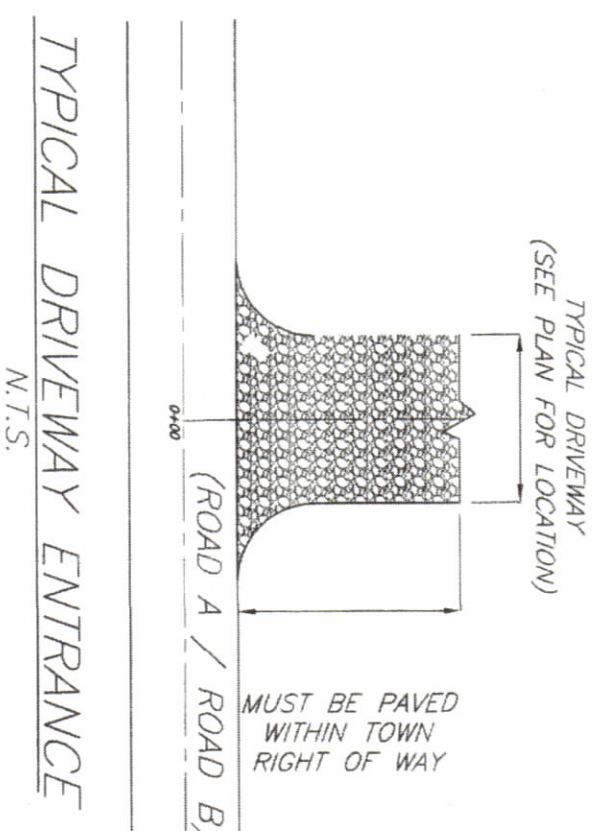

TYPICAL DRIVEWAY ENTRANCE  
 N.T.S.

REV.	DATE	BY	DESCRIPTION
22	01/26/08	D.C.	PER TECHNICAL COMMENTS
21	01/26/08	D.C.	PER TECHNICAL COMMENTS
20	06/20/08	D.C.	GENERAL REVISIONS
19	04/28/08	D.C.	GENERAL REVISIONS
18	02/07/08	D.C.	GENERAL REVISIONS
17	02/07/08	D.C.	GENERAL REVISIONS
16	05/21/08	D.C.	REVISED
15	05/06/08	D.C.	REVISED
14	3/9/08	D.C.	PER TOWN 2/29/08 COMMENTS
13	11/20/07	D.C.	PER TOWN COMMENTS
12	11/20/07	D.C.	PER TOWN COMMENTS
11	06/27/08	D.C.	PER TOWN COMMENTS
10	10/5/08	D.C.	PER TOWN COMMENTS
9	06/27/08	D.C.	PER TOWN COMMENTS
8	6/28/07	D.C.	PER TOWN COMMENTS
7	4/26/07	D.C.	PER TOWN COMMENTS
6	11/8/06	D.C.	PER TOWN COMMENTS
5	07/17/06	D.C.	PER TOWN COMMENTS
4	7/17/06	D.C.	PER TOWN COMMENTS
3	7/17/06	D.C.	PER TOWN COMMENTS
2	5/9/06	D.C.	PER TOWN COMMENTS
1	4/18/06	D.C.	PER TOWN COMMENTS

TOWN OF BEEKMAN PLANNING BOARD  
 APPROVED BY RESOLUTION OF THE PLANNING BOARD OF THE TOWN OF BEEKMAN, NEW YORK ON THE 21<sup>ST</sup> DAY OF JUNE, 2007.  
 SIGNATURE: [Signature]  
 DATE: 2007.20

PROPOSED ROAD ENTRANCE & DRIVEWAY DETAILS  
 Proposed 20 Lot Subdivision  
 LAKE SIDE ESTATES  
 TOWN OF BEEKMAN, DUTCHESS COUNTY, NY

ENGINEER  
 CHARLES T. BROWN, P.E.  
 WILLIAM J. MOREAU, P.E.  
 P.O. BOX 4470  
 NEWburgh, NY 12553  
 (845) 561-2582

JUTNESS COUNTY DEPARTMENT OF HEALTH  
 TOWNHUNTSVILLE, NEW YORK  
 6.20.2007  
 These plans are approved  
 see first sheet for date and signatures

DATE: 3/20/00  
 SCALE: AS NOTED  
 SHEET NUMBER: 10 OF 25